



# Defender™ 5000

Low Profile Scales



## *Smart Functionality, Durability, Ohaus Quality and Value*

The OHAUS Defender™ 5000 Series is a feature-rich line of bench scales, combining an ABS plastic T51P indicator with painted steel bases and columns. Ideal for shipping and receiving, production, packaging and general commercial and industrial weighing applications, the Defender 5000 offers a multifunctional indicator with multiple weighing units and software modes to meet the requirements of industrial and lab applications. With rugged construction, comprehensive yet intuitive software and multiple connectivity options, the Defender 5000 can meet the needs of demanding industrial operations.

### *Standard Features Include:*

- Painted steel bases with ABS indicator
- 10,000-12,500d default resolution for square bases, 5,000-7,500d default resolution for rectangular bases
- Quick display of results using large LCD with high-contrast white backlight
- Temporary display of 10x readability in weighing mode using quick key press
- Easy to operate with 4-key membrane keypad with raised tactile keys
- Weighs in one or more units: kg, g, lb, oz, lb:oz (decimal), tonnes and user-definable custom unit
- Multiple weighing modes including Counting, Percent Weighing, Dynamic/Animal Weighing, Checkweighing, and Display Hold.
- Internal power supply with universal line cord or 6 "C" batteries (80 hour battery life) – optional NiMH internal rechargeable power pack available
- Includes RS232 interface with GMP/GLP data output including date and time
- Base and indicator connected using quick connect plug
- Optional interfaces include DC relay control kit, AC relay control kit, 2nd RS232 and RS485/422

# Defender™ 5000 Low Profile Scales

## The Defender 5000 Offers Multiple Features and Easy Configuration:

To meet different operational needs, the Defender 5000 includes a suite of configurable software:

- Counting mode for packaging and inventory control, enabling counting into a container or out of a container for bulk operations. Supports a maximum counting resolution to 1:300,000 (minimum APW equal to 0.1d), selectable auto-optimization of average piece weight (APW). APW data can be displayed at any time using a quick key press.
- Percent Weighing mode for formulation and mixing applications, with display of reference weight with quick key press.
- Dynamic/Animal Weighing with selectable weigh times from 0-60 seconds.
- Checkweighing function for packaging and weight checking, with display of results using LCD display and red/yellow/green LEDs. Audible beeper can be configured to prompt when weight is within range, under, over, or under or over range. Target weight values can be displayed at any time using a quick key press.
- Display Hold mode for weighing large packages holds last stable weight on display until cleared
- The Defender 5000 weighs in one or more user-selectable units: kg, g, lb, oz, lb:oz (decimal), tonnes and user-definable custom unit
- Supports GMP/GLP data output with date, time user ID, project ID and scale ID. The Defender 5000 features selectable print options for data and print format
- To limit operator access to functions, the Defender 5000 offers both software lockouts for menu items as well as individual key functions.

### Outline Dimensions

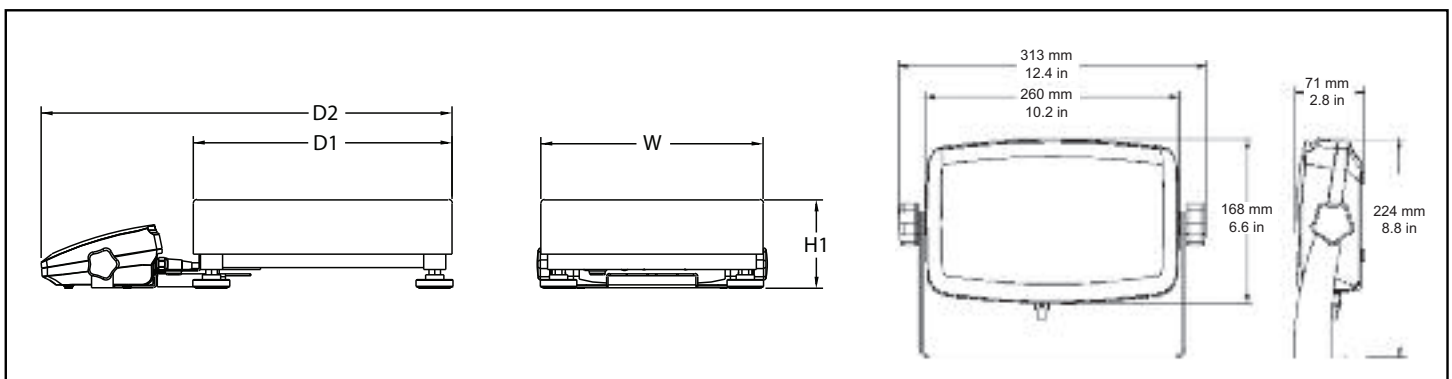

## Standard Features:

### Choice of Two Base Designs

Available in higher-precision square bases or lower-precision rectangular bases.

### Durable Base Frame Construction

Stainless steel pans and painted steel form-and-weld frames (R, L bases) provide maximum durability, rigidity and structural integrity. Load-unload cycle tested to ensure long-term performance.



### Internal Slot for Capacity Label

Protects label from the effects of moisture and external environments

### 3-Color LED

**Checkweigh Indication**  
with configurable beeper alert

### High-Visibility LCD Display

with bright white LED back-light and fast display stable weight within 2 seconds

### Fully Adjustable Feet

Four rugged, adjustable feet help prevent slippage on wet or uneven surfaces

### Universal Switching

**Power Supply**  
100-240 VAC with AC line cord; no need for an external AC adapter!



### Simple Plug-In Battery Installation

Use six C- alkaline batteries or the optional NiMH battery



### Stay Connected

Built in RS232 bi-directional interface and, external input, optional RS485/422, optional second RS232 and optional AC or DC relay

### One-Key, Multiple Mode Selection

Counting, Dynamic Weighing, Display Hold, Percent Weighing and Checkweighing

### Reinforced Indicator Housing

Internal structural ribs provide strength and minimize flexing.



## Options and Accessories

### Interface Options

	OHAUS Number
AC Relay Kit .....	80500720
DC Relay Kit .....	80500727
RS485/422 Interface Kit .....	80500731
Second RS232 Interface Kit .....	80500733
Foot Switch .....	71173378

### Power Options

Rechargeable Battery Kit, T51P/T51XW .....	80500729
--	----------

### Other Accessories

RS232 Cable to SF42 Printer .....	80500571
RS232 Cable to PC 25-pin .....	80500524
RS232 Cable to PC 9-pin .....	80500525
Compact Impact Printer, 42 Column .....	SF42
Paper for SF42 printer (5 pack) .....	12101511
Ribbon for SF42 printer .....	12101512

# Defender™ 5000 Low Profile Scales

## Low-Profile Square Scales

Model	D51P10QR5	D51P25QR5	D51P50QL5	D51P100QL5	D51P250QX5
Capacity (max) x Default Readability (d)	25 lb x 0.002 lb 400 oz x 0.05 oz 25 lb : 0.05 oz 10 kg x 0.001 kg 10000 g x 1 g	50 lb x 0.005 lb 800 oz x 0.1 oz 50 lb x 0.1 oz 25 kg x 0.002 kg 25000 g x 2 g	100 lb x 0.01 lb 1600 oz x 0.2 oz 160 lb : 0.2 oz 50 kg x 0.005 kg 50000 g x 5 g	250 lb x 0.02 lb 4000 oz x .5 oz 250 lb : .5 oz 100 kg x 0.01 kg 100000 g x 10 g	500 lb x 0.05 lb 8000 oz x 1 oz 500 lb : 1 oz 250 kg x 0.02 kg 250000 g x 20 g
Maximum Displayed Resolution	1:12500	1:12500	1:10000	1:12500	1:12500
Scale Dimensions (W x H1 x D1 x D2)	12 x 3.7 x 12 x 20.8 in 305 x 95 x 305 x 530 mm		18 x 4.5 x 18 x 26.8 in 457 x 115 x 457 x 680 mm		24 x 5.4 x 24 x 32.8 in 610 x 137 x 610 x 833 mm
Shipping Dimensions (L x W x H)	19.3 x 16.1 x 17.3 in 490 x 410 x 440 mm		31.2 x 23.6 x 9.5 in 810 x 600 x 240 mm		39.4 x 29.9 x 9.8 in 1000 x 760 x 250 mm
Net Weight	30.6 lb / 13.9 kg		63.7 lb / 28.9 kg		80.9 lb / 36.7 kg
Shipping Weight	35.9 lb / 16.3 kg		68.5 lb / 31.1 kg		95.0 lb / 43.1 kg

## Low-Profile Rectangular Scales

Model	D51P15HR5	D51P30HR5	D51P60HR5	D51P60HL5	D51P100HL5	D51P150HX5	D51P300HX5
Capacity (max) x Default Readability (d)	30lb x 0.005lb 480oz x 0.1oz 30lb : 0.1oz 15kg x 0.002kg 15000g x 2g	60lb x 0.01lb 960oz x 0.2oz 60lb x 0.2oz 30kg x 0.005kg 30000g x 5g	150lb x 0.02lb 2400oz x 0.5oz 160lb : 0.5oz 60kg x 0.01kg 60000g x 10g		250lb x 0.05lb 4000oz x 1oz 250lb : 1oz 100kg x 0.02kg 100000g x 20g	300lb x 0.05lb 4800oz x 1oz 300lb : 1oz 150kg x 0.02kg 150000g x 20g	600lb x 0.1lb 9600oz x 2oz 600lb : 2oz 300kg x 0.05kg 300000g x 50g
Maximum Displayed Resolution	1:7500	1:6000	1:7500		1:5000	1:7500	1:6000
Scale Dimensions (W x H1 x D1 x D2)	12 x 3.7 x 14 x 22.8 in 305 x 95 x 355 x 580 mm			15.7 x 4.1 x 19.7 x 28.5 in 400 x 105 x 500 x 725 mm		16.5 x 4.9 x 21.7 x 30.5 in 420 x 125 x 550 x 775 mm	
Shipping Dimensions (L x W x H)	19.3 x 16.1 x 17.3 in 490 x 410 x 440 mm			29.1 x 27.2 x 9.1 in 740 x 690 x 230 mm		29.5 x 30 x 9.1 in 750 x 710 x 230 mm	
Net Weight	23.6 lb / 10.7 kg			46.3 lb / 21.0 kg		58.2 lb / 26.4 kg	
Shipping Weight	35.9 lb / 12.7 kg			53.6 lb / 24.3 kg		64.8 lb / 29.4 kg	

## General Specifications

Indicator Model	T51P
Construction	ABS plastic indicator, stainless steel removable weighing platform, aluminum loadcell, painted steel mounting bracket and base construction
Safe Overload Capacity	150% of maximum capacity
Weighing Units	lb, oz, lb:oz, kg, g, custom unit
Modes	Static Weighing, Dynamic Weighing, Counting, Checkweighing, Percent Weighing, Display Hold
Display	1 in / 25mm high 6-digit, 7-segment bright white backlit LCD
Keyboard	4-button membrane switch
Stabilization Time	Within 2 seconds
Auto-zero Tracking	Off, 0.5, 1 or 3 d
Zeroing Range	2% or 100% of capacity
Calibration	Span: 1kg or 1lb to 100% of capacity / 3-point linearity (0 - 50% - 100% fixed)
Power	100-240 VAC / 50-60Hz internal universal power supply, 6 "C" cell batteries (not supplied) with 80 hour life
Interface	RS232 and external input
Operating Temperature Range	14°F to 104°F / -10°C to 40°C

## Features

**T51P:** ABS plastic housing with internal rib reinforcements, reversible rear cover, backlit LCD weight display, checkweighing indication (green, yellow, red), membrane keypad with raised tactile keys, built-in bi-directional RS232 with manual/continuous/interval printing, external tare input, hardware configuration lockout switch, internal switching power supply with line cord and battery power using 6 "C" cell batteries.

## Other Features

Zero point calibration, calibration test, span or linear calibration, selectable auto-zero tracking range, selectable stability range, selectable averaging level, selectable LCD backlight, selectable auto shutoff, retain zero weight data after power-off, Geo gravity adjustment, selectable key beep, key function lock, menu lock, selectable power-on and calibration unit, battery status display, display of gross/net weight, indication of stability, center of zero, over and underweight, overload and underload conditions. Configuration menus for PRINT1, PRINT2, COM1, COM2, and I/O.

## Compliance

- **Safety and EMC:** cUL<sub>US</sub> 2005/95/EC low voltage directive: EN60950-1:2001, FCC Part 15 Class A 2004/108/EC Compliant to Directive 202/96/EC on waste electrical and electronic equipment (WEEE)
- **Quality:** OHAUS quality management system registered to ISO 9001:2000

## Ohaus Corporation

\* 19A Chapin Road  
P.O. Box 2033  
Pine Brook, NJ 07058 USA

Tel: 800.672.7722  
973.377.9000  
Fax: 973.593.0359

www.ohaus.com

With offices throughout Europe,  
Asia, and Latin America

## \* ISO 9001

Registered Quality Management System

