



# Defender™ 5000X

Xtreme Rectangular Scales



## *Smart Functionality, Durability, Ohaus Quality and Value*

The OHAUS Defender™ 5000 Series is a feature-rich line of bench scales, combining a stainless steel D51XW indicator with a rectangular, painted steel base and a painted steel column. Ideal for shipping and receiving, production, packaging and general commercial and industrial weighing applications, the Defender 5000 offers a multifunctional indicator with multiple weighing units and software modes to meet the requirements of industrial and lab applications. With rugged steel construction, comprehensive yet intuitive software and multiple connectivity options, the Defender 5000 can meet the needs of demanding industrial operations.

### *Standard Features Include:*

- All steel construction with stainless steel indicator and painted steel column and base
- 5,000-7,500d default resolution
- Quick display of results using large LCD with high-contrast white backlight
- Temporary display of 10x readability in weighing mode with quick key press
- Easy to operate with 4-key membrane keypad with raised tactile keys
- Weighs in one or more units: kg, g, lb, oz, lb:oz (decimal), tonnes and user-definable custom unit
- Multiple weighing modes including Counting, Percent Weighing, Dynamic/Animal Weighing, Checkweighing, and Display Hold.
- Internal universal switching power supply with hardwired line cord – optional NiMH internal rechargeable power pack available
- Includes RS232 interface with GMP/GLP data output including date and time
- Optional interfaces include DC relay control kit, AC relay control kit, 2nd RS232 and RS422/485

# Defender™ 5000X Xtreme Rectangular

## The Defender 5000 Offers Multiple Features and Easy Configuration:

To meet different operational needs, the Defender 5000 includes a suite of configurable software:

- Counting mode for packaging and inventory control, enabling counting into a container or out of a container for bulk operations. Supports a maximum counting resolution to 1:300,000 (minimum APW equal to 0.1d), selectable auto-optimization of average piece weight (APW). APW data can be displayed at any time using a quick key press
- Percent Weighing mode for formulation and mixing applications, with display of reference weight with quick key press
- Dynamic/Animal Weighing with selectable weigh times from 0-60 seconds
- Checkweighing function for packaging and weight checking, with display of results using LCD display and red/yellow/green LEDs. Audible beeper can be configured to prompt when weight is within range, under, over, or under or over range. Target weight values can be displayed at any time using a quick key press
- Display Hold mode for weighing large packages holds last stable weight on display until cleared
- The Defender 5000 weighs in one or more user-selectable units: kg, g, lb, oz, lb:oz (decimal), tonnes and user-definable custom unit
- Supports GMP/GLP data output with date, time user ID, project ID and scale ID. The Defender 5000 features selectable print options for data and print format
- To limit operator access to functions, the Defender 5000 offers both software lockouts for menu items as well as individual key functions

### Outline Dimensions

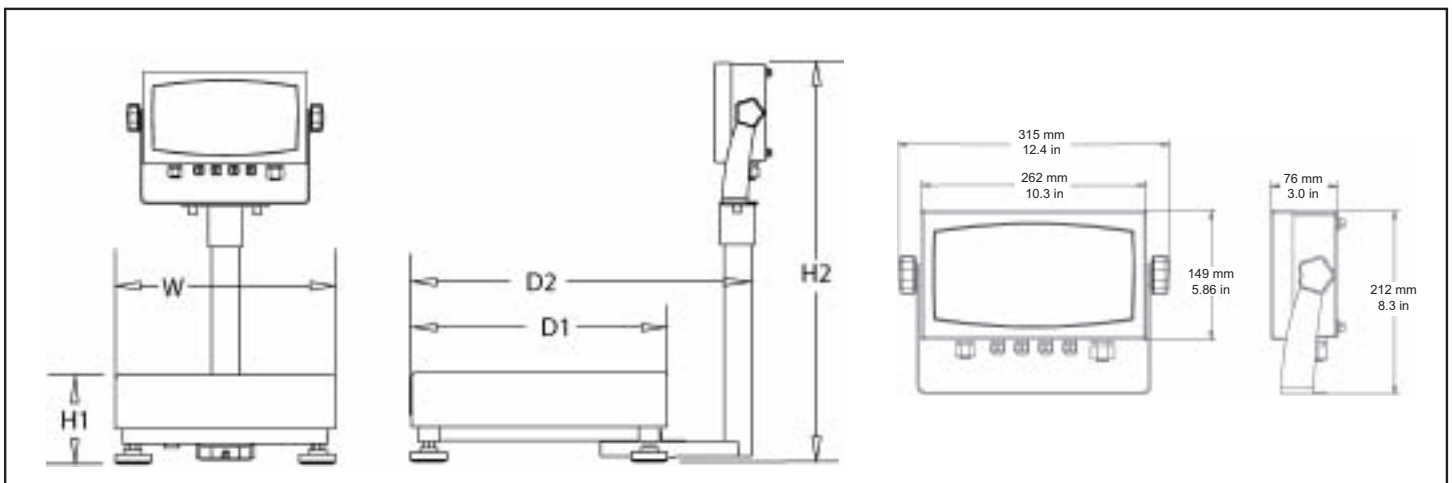

## Standard Features

**Optional NiMH Battery**

Allows for use in environments where an electrical outlet may not be readily available

**Internal Slot for Capacity Label**

Protects label from the effects of moisture and external environments

**Stainless Steel 304 NEMA 4X/IP66 Enclosure**

Indoor/outdoor protection against falling dirt, rain, sleet, snow, windblown dust, splashing and corrosion



**3-Color LED Checkweigh Indication**

with configurable beeper alert

**High-Visibility LCD Display**

with bright white LED backlight and fast display stable weight within 2 seconds

**Included Table/Wall Mount Bracket**

With large ergonomic adjustable knobs to maximize viewing angles.

**One-Key, Multiple Mode Selection**

Counting, Dynamic Weighing, Display Hold, Percent Weighing and Checkweighing

**Hinged Front Cover**

Only four sealing screws secure the housing for ease of servicing, while still ensuring IP66 seal integrity



**Universal Switching Power Supply**

Automatically adapts to different voltages and frequencies; plug anywhere, anytime

**Stay Connected**

Built in RS232 bi-directional interface and external input, optional RS485/422, optional second RS232 and optional AC or DC relay

**Painted Steel Columns**

Available in both short and tall lengths

**Durable Base Frame Construction**

Stainless steel pans and painted steel form-and-weld frames (R, L bases) provide maximum durability, rigidity and structural integrity. Load-unload cycle tested to ensure long-term performance.



**Fully Adjustable Feet**

Four rugged, adjustable feet help prevent slippage on wet or uneven surfaces

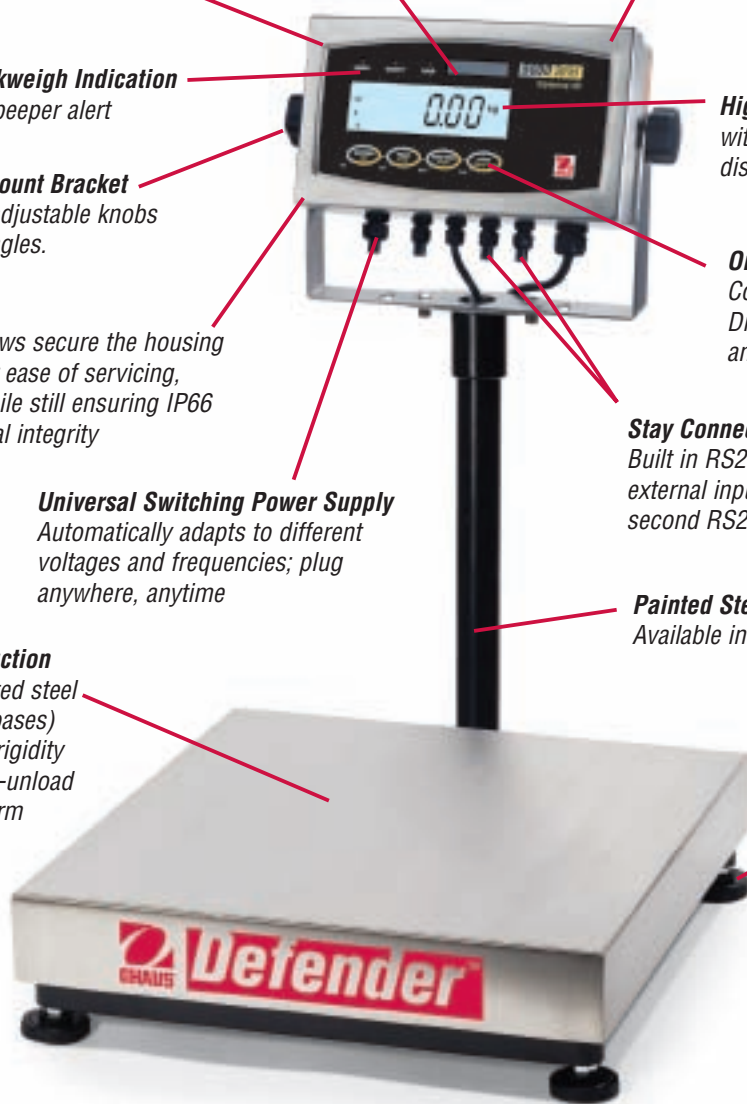

**Options and Accessories**

**Interface Options**

	<b>OHAUS Number</b>
AC Relay Kit.....	80500720
DC Relay Kit.....	80500727
RS422/485 Interface Kit .....	80500731
Second RS232 Interface Kit.....	80500733
Foot Switch .....	71173378

**Power Options**

Rechargeable Battery Kit, T51P/T51XW.....	80500729
---	----------

**Other Accessories**

RS232 Cable to SF42 Printer .....	80500574
RS232 Cable to PC 25-pin .....	80500553
RS232 Cable to PC 9-pin .....	80500552
Compact Impact Printer, 42 Column .....	SF42
Paper for SF42 printer (5 pack) .....	12101511
Ribbon for SF42 printer .....	12101512

# Defender™ 500X Rectangular Scales

## Specifications

Model	D51XW15HR1	D51XW30HR1	D51XW60HR1	D51XW60HL2	D51XW100HL2	D51XW150HX2	D51XW300HX2
Capacity (max) x Default Readability (d)	30lb x 0.005lb 480oz x 0.1oz 30lb : 0.1oz 15kg x 0.002kg 15000g x 2g	60lb x 0.01lb 960oz x 0.2oz 60lb x 0.2oz 30kg x 0.005kg 30000g x 5g	150lb x 0.02lb 2400oz x 0.5oz 160lb : 0.5oz 60kg x 0.01kg 60000g x 10g	250lb x 0.05lb 4000oz x 1oz 250lb : 1oz 100kg x 0.02kg 100000g x 20g	300lb x 0.05lb 4800oz x 1oz 300lb : 1oz 150kg x 0.02kg 150000g x 20g	600lb x 0.1lb 9600oz x 2oz 600lb : 2oz 300kg x 0.05kg 300000g x 50g	
Maximum Displayed Resolution	1:7500	1:6000	1:7500	1:5000	1:7500	1:6000	
Indicator Model	T51XW						
Column	13.8 in / 350 mm painted steel			26.8 in / 680 mm painted steel			
Construction	Stainless steel indicator, removable weighing platform, painted steel column and base construction, aluminum loadcell						
Safe Overload Capacity	150% of maximum capacity						
Protection	NEMA 4X/IP66 for indicator, IP67 for loadcell						
Weighing Units	lb, oz, lb:oz, kg, g, custom unit						
Modes	Static Weighing, Dynamic Weighing, Counting, Checkweighing, Percent Weighing, Display Hold						
Display	1 in / 25 mm high 6-digit, 7-segment bright white backlit LCD						
Keyboard	4-button membrane switch						
Stabilization Time	Within 2 seconds						
Auto-zero Tracking	Off, 0.5, 1 or 3 d						
Zeroing Range	2% or 100% of capacity						
Calibration	Span: 1kg or 1lb to 100% of capacity / 3-point linearity (0 - 50% - 100% fixed)						
Power	100-240 VAC / 50-60Hz internal universal power supply						
Interface	RS232 and external input						
Operating Temperature Range	14°F to 104°F / -10°C to 40°C						
Scale Dimensions (W x H1 x H2 x D1 x D2)	12 x 3.7 x 23.6 x 14 x 18.7 in 305 x 95 x 600 x 355 x 475 mm			15.7 x 4.1 x 37 x 19.7 x 24.4 in 400 x 105 x 940 x 500 x 620 mm		16.5 x 4.9 x 37 x 21.7 x 26.4 in 420 x 125 x 940 x 550 x 670 mm	
Shipping Dimensions (L x W x H)	19.3 x 16.1 x 17.3 in 490 x 410 x 440 mm			29.1 x 27.2 x 9.1 in 740 x 690 x 230 mm		29.5 x 30 x 9.1 in 750 x 710 x 230 mm	
Approx. Net Weight	28.4 lb / 12.9 kg			52.2 lb / 23.7 kg		64.1 lb / 29.1 kg	
Approx. Shipping Weight	33.3 lb / 15.1 kg			59.5 lb / 27 kg		70.7 lb / 32.1 kg	

## Features

**T51XW:** Stainless steel water resistant NEMA 4X / IP66 housing, integral faceplate supports for easy servicing, backlit LCD weight display, checkweighing indication (green, yellow, red), membrane keypad with raised tactile keys, built-in bi-directional RS232 with manual/continuous/interval printing, external tare input, hardware configuration lockout switch, internal switching power supply with hardwired cord.

## Other Features

Zero point calibration, calibration test, span or linear calibration, selectable auto-zero tracking range, selectable stability range, selectable averaging level, selectable LCD backlight, selectable auto shutoff, retain zero weight data after power-off, Geo gravity adjustment, selectable key beep, key function lock, menu lock, selectable power-on and calibration unit, battery status display, display of gross/net weight, indication of stability, center of zero, over- and underweight, overload and underload conditions. Configuration menus for PRINT1, PRINT2, COM1, COM2, and I/O.

## Compliance

- **Safety and EMC:** cUL<sub>US</sub> 2005/95/EC low voltage directive: EN60950-1:2001, FCC Part 15 Class A 2004/108/EC EMC directive: EN61326-1:1997; +A1:1998; +A2:2001; + A3>2003
- **Other:** Compliant to Directive 2002/96/EC on waste electrical and electronic equipment (WEEE)
- **Quality:** Ohaus quality management system registered to ISO 9001:2000

## Ohaus Corporation

\* 19A Chapin Road  
P.O. Box 2033  
Pine Brook, NJ 07058 USA

Tel: 800.672.7722  
973.377.9000  
Fax: 973.593.0359

www.ohaus.com

With offices throughout Europe,  
Asia, and Latin America

\* **ISO 9001**  
Registered Quality Management System

80774413 © Copyright Ohaus Corporation

