



The perfect portable balance when cost matters and dependable results are a must!

The OHAUS CS Compact Scale is a lightweight, portable scale perfectly suited for use in laboratory, industrial, education and home use applications. Applications can include forensic testing, quality control, formulation, soil sampling, postal weighing and dietary needs.

Standard Features Include:

- **Superior RF Protection** – The CS is designed with superior RF protection to deliver accurate and stable results when used in production areas or near cell phones. Approvals for electrical and emissions include CE listed and FCC Class B Part 15 operation.
- **Large Stainless Steel Weighing Platform** – The CS is designed with a large weighing platform and can adequately handle large samples including oversized letters. In addition, the standard stainless steel platform is removable for easy cleaning.
- **Compact Design** – The CS has a low profile design and is truly portable when powered by three “AA” batteries (included). A standard AC adapter can also be used to power the CS, when used in a more permanent location.

CS Series Compact Scales

Specifications

Model	CS200	CS2000	CS5000
Capacity x Readability (g)	200 g x 0.1 g	2000 g x 1 g	5000 g x 1 g
Repeatability (Std. dev.) (g)	0.1	1	1
Linearity (g)	±0.1	±1	±1
Weighing units	g, lb:oz, Newton		
Zero range	To capacity by subtraction		
Stabilization time	3 seconds		
Optimum operating temp.	65°-77°F / 18°-25°C at 10% to 80% relative humidity, non-condensing		
Power requirements	3-AA alkaline batteries (included) or AC adapter (included)		
Calibration	User calibration from keypad		
Auto shut-off	5 minutes no activity (battery operation only)		
Display (in/mm)	LCD (0.4 / 11)		
Pan size L x W (in/cm)	5.75 x 5.25 / 14.5 x 13.3		
Dimensions L x W x H (in/cm)	8.0 x 5.5 x 1.5 / 20.3 x 14.0 x 3.8		
Net Weight (lb/kg)	.91 / .47		

Additional Models

Also available are the CS200P, CS200P and CS500P, which include a US postal chart.

Standard Features

Easy operation with two clearly marked buttons, low battery indicator and auto shut-off feature to conserve battery life, mechanical and software overload protection to protect weighing cell from damage, external push button calibration (calibration masses not included).

Options and Accessories

Ohaus Number

1050 ml capacity plastic bowl.....80850075
 Calibration massesCall Ohaus for details

Industry Leading Quality and Support

All Ohaus CS Series scales are manufactured under an ISO 9001:2000 Registered Quality Management System. Our rugged construction and stringent quality control have been hallmarks of all Ohaus products for over a century.

Outline Dimensions

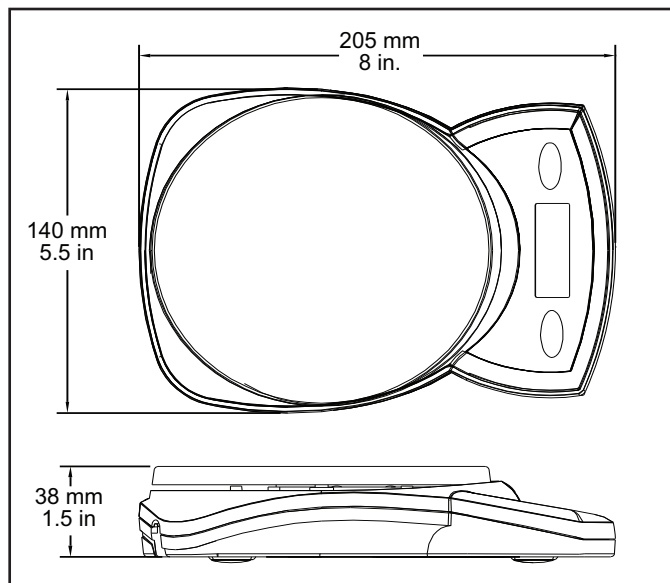

Ohaus Corporation

* 19A Chapin Road
 P.O. Box 2033
 Pine Brook, NJ 07058 USA

Tel: 800.672.7722
 973.377.9000
 Fax: 973.944.7177

www.ohaus.com

*With offices throughout Europe,
 Asia, and Latin America*

* **ISO 9001:2000**
 Registered Quality Management System

8077373 © Copyright Ohaus Corporation

