

DKS-3002

A portable, compact, digital portion control scale...



by **Yamato**

DIGITAL SCALE

DKS-3002

Auto Shut-Off

Electronic Features

Microprocessor based, the circuitry and software of these fine scales provide an array of valuable functions, ALL STANDARD, such as:

- Initial, Automatic and Semi-automatic Zero setting
- Automatic display check of all digital segments and annunciators
- Zero tracking (which restores "true" zero after each weighing)
- Choice of units of weight (pounds and decimal ounces or grams)
- Automatic shut-off to prolong battery life

Quality construction

The DKS series scale is constructed with a durable plastic housing and quality components throughout to guarantee trouble-free operation.

Easy to read

The large (0.5") LCD display is easy to read under any lighting condition, whether standing up or sitting down. Weights are displayed within a fraction of a second.

Sanitary

The sturdy plastic housing, keypad and optional stainless steel platform are easy to keep clean. The scale wipes clean with a damp cloth.

Affordable

Specifications

Model	DKS-3002	
Capacity and Division	Low Range 0 g to 1000 g x 1 g 4 lb x 0.1 oz	High Range 1000 g to 2000 g x 2 g No Dual Range
Platform	5.9 x 4.7 (150 x 120); Stainless Steel (optional)	
Indicator	LCD with 4 active digits Character size: 0.5" x 0.3" (12 x 7)	
Power Supply	9 V DC or AC Adaptor	
Operating Temp.	32°F ~ 104°F (0°C ~ 40°C)	
Shipping Weight	2 lb (0.9 kg)	

*Three Month Warranty

Accurate reading of weight values

The DKS offers both pound and gram capacities. Units of weight can be switched from lb/oz to grams by simply pressing one clearly marked key. A "dual-range" system used in these scales permits fine weight readings in increments as small as 1 g or 0.1oz.

Options

- A/C Adaptor
- Stainless Steel Platform Cover

All weights and dimensions are approximate. Dimensions are given in inches and (millimeters).

Dimensions

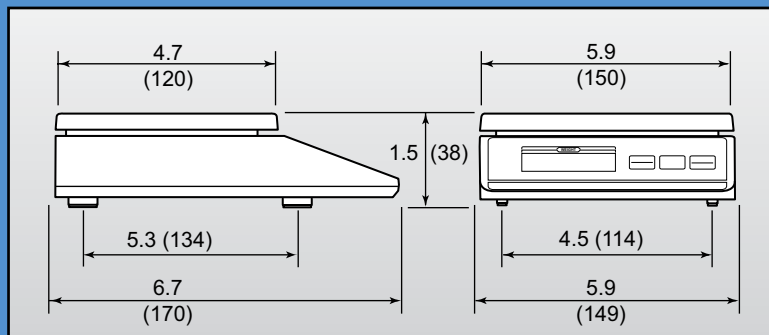

Front Panel

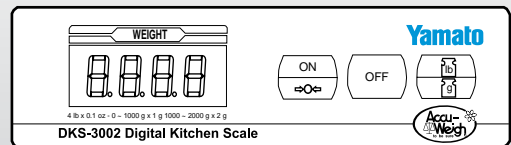

Yamato
www.YamatoCorp.com

Yamato Corporation
P.O. Box 15070
Colorado Springs, CO 80935-5070
U.S.A.
Tel (719) 591-1500
Fax (719) 591-1045

Yamato Tech Corporation
#112-19425 Langley By-Pass
Surrey, B.C. V3S 6K1
Canada
Tel (604) 533-2338
Fax (604) 533-0827

YCO-1095-01-02 Printed in U.S.A.